

SFP+ 10G 1550nm 40Km ER

TCM10G15ER

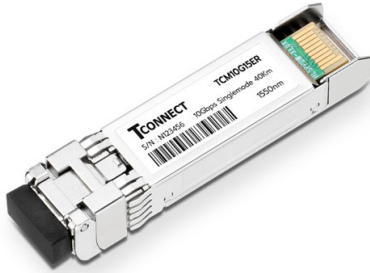

Overview

SFP+ER 1550nm Transceiver is a “Limiting module”, designed for 10GBASE-ER, and 2G/4G/ 8G/10G Fiber- Channel applications.

The transceiver consists of two sections: The transmitter section incorporates a colded EML laser. And the receiver section consists of a PIN photodiode integrated with a TIA. All modules satisfy class I laser safety requirements. Digital diagnostics functions are available via a 2-wire serial interface, as specified in SFF-8472, which allows real-time access to device operating parameters such as transceiver temperature, laser bias current, transmitted optical power, received optical power, and transceiver supply voltage.

Ordering information

Part Number	Product Description
TCM10G15ER	SFP+ 10Gbps, 1550nm, 40km, -5°C ~ +70°C

Features

- ◆ Compliant with SFF-8431,SFF-8432 and IEE802.3ae
- ◆ 10GBASE-ER, and 2G/4G/ 8G/10G Fiber Channel applications.
- ◆ Cooled EML transmitter and PIN receiver
- ◆ link length up to 40km
- ◆ Low Power Dissipation 1.5W Maximum
- ◆ -5°C to 70°C Operating Case Temperature
- ◆ Single 3.3V power supply
- ◆ Diagnostic Performance Monitoring of module temperature, supply
- ◆ Voltages, laser bias current, transmit optical power, receive optical power

Applications

- ◆ 10GBASE-ER (with/without FEC)
- ◆ 10G Fiber Channel (with/without FEC)

Datasheet

Module Block Diagram

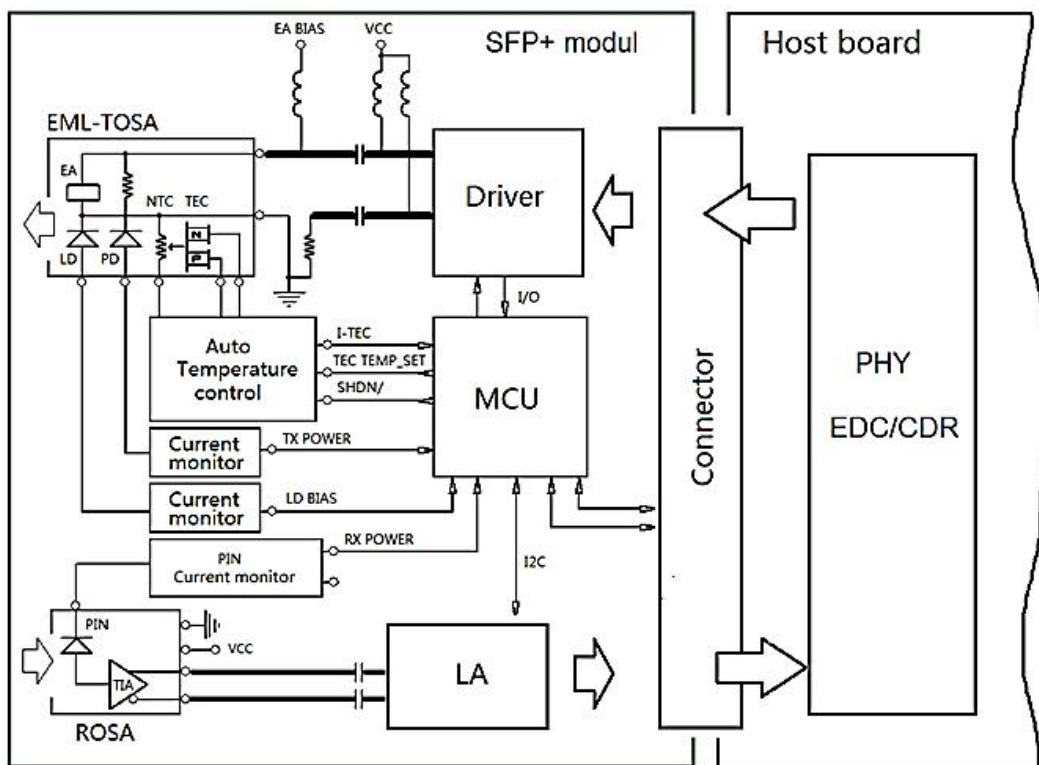

Figure1. Module Block Diagram

Absolute Maximum Ratings

Parameter	Symbol	Min	Max	Unit
Supply Voltage	Vcc	-0.5	3.8	V
Storage Temperature	Tst	-40	85	°C
Relative Humidity	Rh	0	85	%

Operating Conditions

Parameter	Symbol	Min	Typical	Max	Unit
Supply Voltage	Vcc	3.13	3.3	3.46	V
Supply current	Icc	-	360	450	mA
Operating Case temperature	Tca	-5	-	70	°C
Module Power Dissipation	Pm	-	1.2	1.5	W

Transmitter Specifications – Optical

Parameter	Symbol	Min	Typical	Max	Unit
Center Wavelength	λ_c	1530		1565	nm
Spectral Width (-20dB)	$\Delta\lambda_{20}$	-	-	0.3	nm
Average Optical Power	Po	-4.7	-	+4	dBm

Datasheet

Optical Power in OMA	OMA	-2.1			dBm
Side Mode Suppression Ratio	SMSR	30	-	-	dB
Optical Transmit Power (disabled)	PTX_DISABLE	-	-	-30	dBm
Extinction Ratio	ER	8.2	-	-	dB
Relative Intensity Noise	RIN	-	-	-128	dB/Hz
Optical Return Loss Tolerance	Orl	-	-	21	dB

Receiver Specifications – Optical

Parameter	Symbol	Min	Typical	Max	Unit
Input Operating Wavelength	λ	1260	-	1600	nm
Average receive power	Pavg	-15.8	-	-1.0	dBm
Receiver sensitivity in 10.3Gbps(OMA)	Rsen1	-	-	-14.1	dBm
Stressed receiver sensitivity in 10.3Gbps(OMA)	Rsen2	-	-	-11.3	dBm
Reflectance	Rrx	-	-	-26	dB
LOS Asserted	Lsa	-28	-	-	dBm
LOS De-Asserted	Lda	-	-	-19	dBm
LOS Hysteresis	Lh	0.5	-	-	dB

Notes:

- [1] Measured with conformance test signal for BER = 10^{-12} . The stressed sensitivity values in the table are for system level BER measurements which include the effects of CDR circuits. It is recommended that at least 0.4 dB additional margin be allocated if component level measurements are made without the effects of CDR circuits.

Transmitter Specifications – Electrical

Parameter	Symbol	Min	Typical	Max	Unit
Data Rate	Mra	1.0	10.3	11.3	Gbps
Input differential impedance	Rim	-	100	-	Ω
Differential data Input	VtxDIFF	120	-	850	mV
Transmit Disable Voltage	VD	2.0	-	Vcc3+0.3	V
Transmit Enable Voltage	Ven	0	-	+0.8	V
Transmit Disable Assert Time	Vn	-	-	100	us

Receiver Specifications – Electrical

Parameter	Symbol	Min	Typical	Max	Unit
Data Rate	Mra	-	10.3	11.3	Gbps
Differential Output Swing	Vout P-P	350	-	850	mV
Rise/Fall Time	Tr / Tf	24	-	-	ps
Loss of Signal –Asserted	VOH	2	-	Vcc3+0.3-	V
Loss of Signal –Negated	VOL	0	-	+0.4	V

Datasheet

Digital Diagnostic Functions

Parameter	Symbol	Min.	Max	Unit	Notes
Accuracy					
Transceiver Temperature	DMI_Temp	-3	+3	degC	Over operating temp
TX Output optical power	DMI_TX	-3	+3	dB	
RX Input optical power	DMI_RX	-3	+3	dB	-3dBm to -12dBm range
Transceiver Supply voltage	DMI_VCC	-0.08	+0.08	V	Full operating range
Bias current monitor	DMI_Ibias	-10%	10%	mA	
Dynamic Range Accuracy					
Transceiver Temperature	DMI_Temp	-5	70	degC	
TX Output optical power	DMI_TX	-1	+2	dBm	
RX Input optical power	DMI_RX	-18	0	dBm	
Transceiver Supply voltage	DMI_VCC	3.0	3.6	V	
Bias current monitor	DMI_Ibias	0	100	mA	

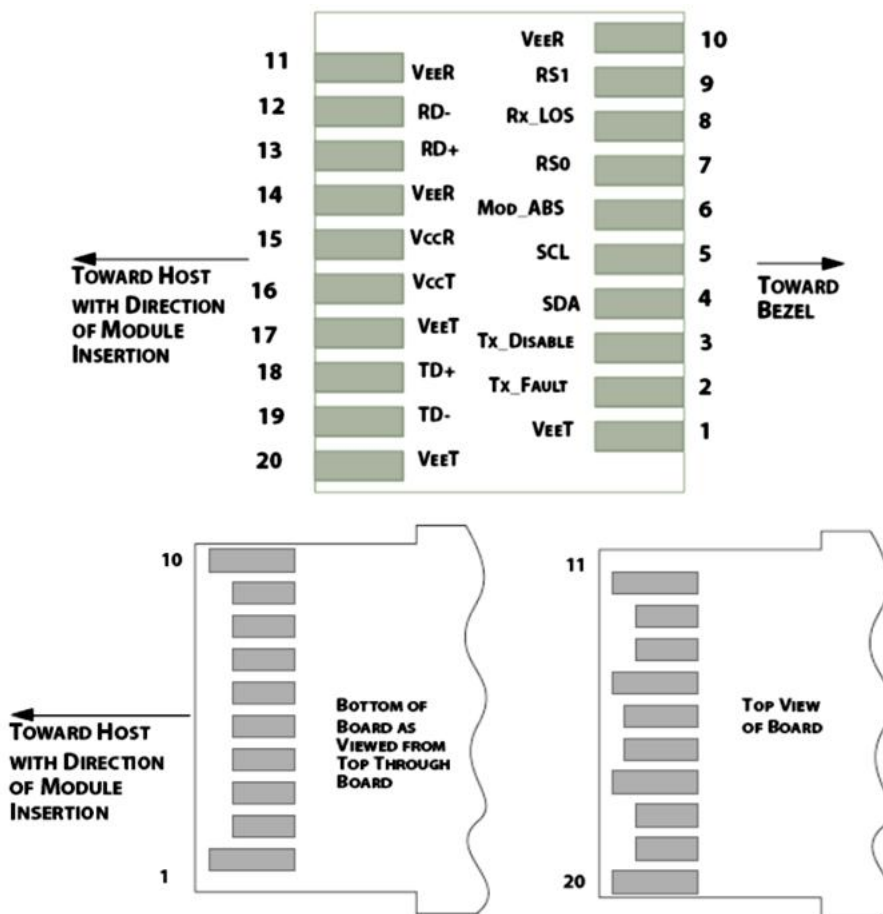

Figure2. Electrical Pin-out Details

Datasheet

Pin Descriptions

Pin	Symbol	Name/Description												
1	VEET [1]	Transmitter Ground												
2	Tx_FAULT [2]	Transmitter Fault												
3	Tx_DIS [3]	Transmitter Disable. Laser output disabled on high or open												
4	SDA [2]	2-wire Serial Interface Data Line												
5	SCL [2]	2-wire Serial Interface Clock Line												
6	MOD_ABS [4]	Module Absent. Grounded within the module												
7	RS0 [5]	Rate Select 0												
8	RX_LOS [2]	Loss of Signal indication. Logic 0 indicates normal operation												
9	RS1 [5]	Rate Select 1												
10	VEER [1]	Receiver Ground												
11	VEER [1]	Receiver Ground												
12	RD-	Receiver Inverted DATA out. AC Coupled												
13	RD+	Receiver DATA out. AC Coupled												
14	VEER [1]	Receiver Ground												
15	VCCR	Receiver Power Supply												
16	VCCT	Transmitter Power Supply	17	VEET [1]	Transmitter Ground	18	TD+	Transmitter DATA in. AC Coupled	19	TD-	Transmitter Inverted DATA in. AC Coupled	20	VEET [1]	Transmitter Ground
17	VEET [1]	Transmitter Ground												
18	TD+	Transmitter DATA in. AC Coupled												
19	TD-	Transmitter Inverted DATA in. AC Coupled												
20	VEET [1]	Transmitter Ground												

Notes:

- [1]. Module circuit ground is isolated from module chassis ground within the module.
- [2]. Should be pulled up with 4.7k – 10k ohms on host board to a voltage between 3.15V and 3.6V.
- [3]. Tx_Disable is an input contact with a 4.7 kΩ to 10 kΩ pullup to VccT inside the module.
- [4]. Mod_ABS is connected to VeeT or VeeR in the SFP+ module. The host may pull this contact up to Vcc_Host with a resistor in the range 4.7 kΩ to 10 kΩ. Mod_ABS is asserted “High” when the SFP+ module is physically absent from a host slot.
- [5]. RS0 and RS1 are module inputs and are pulled low to VeeT with > 30 kΩ resistors in the module.

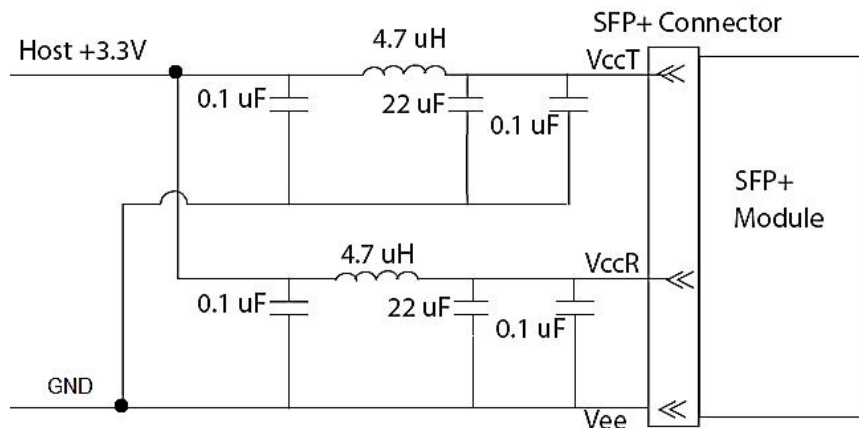

Figure3. Host Board Power Supply Filters Circuit

Datasheet

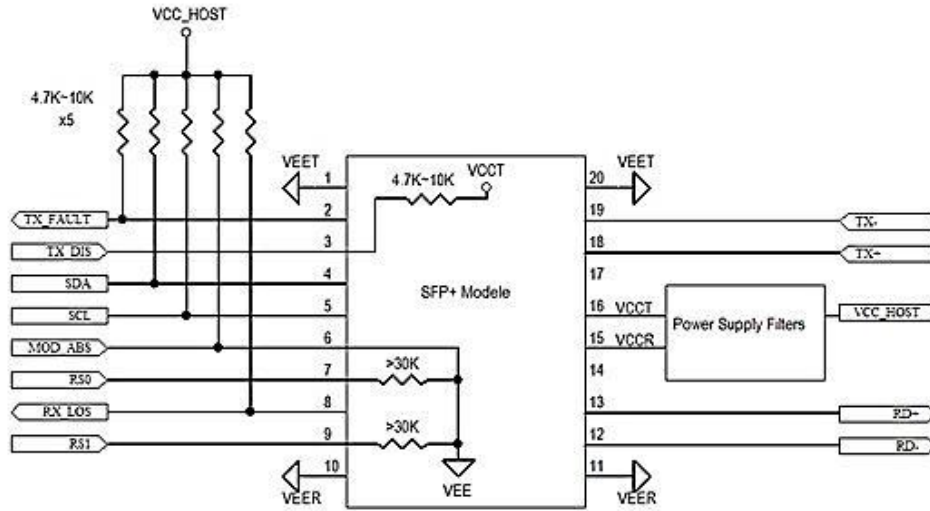

Figure4. Host-Module Interface

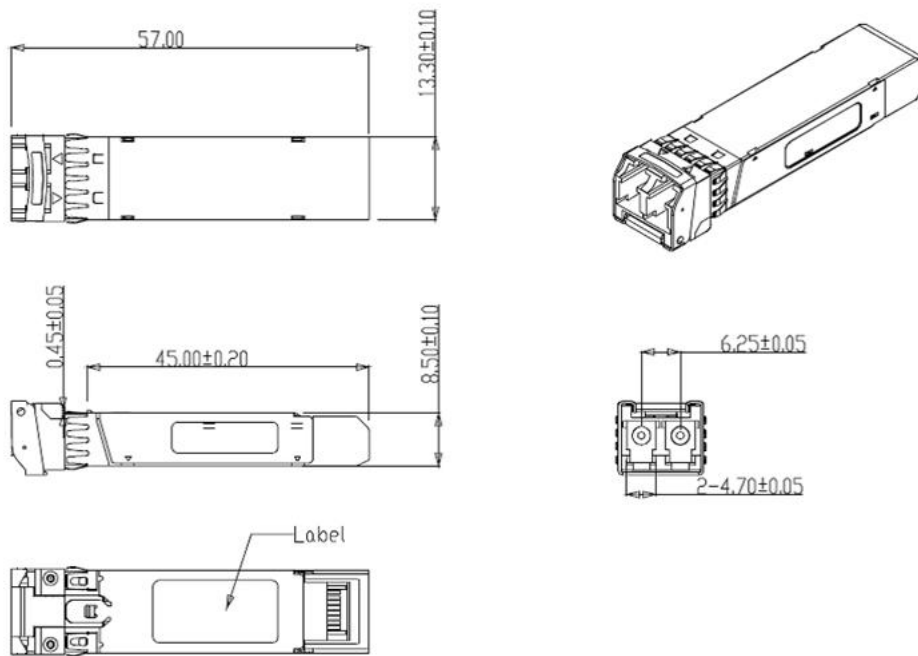

Figure5. Mechanical Specifications

ITK Connecting Co.,Ltd.

ITK Connecting reserves the right to make changes to or discontinue any optical link product or service identified in this document without notice in order to improve design and/or performance. If you have any question regarding this specification sheet, please contact our sales representative or send email to sales@itk.co.th